

Established 1962

**Chas.
Hawkins
Company
Inc.**

COMMERCIAL REAL ESTATE

CORFAC
International

CHAS. HAWKINS Co., Inc. / CORFAC INTERNATIONAL

AVAILABLE FOR LEASE

3212 WEST END AVE – WESTPARK BUILDING

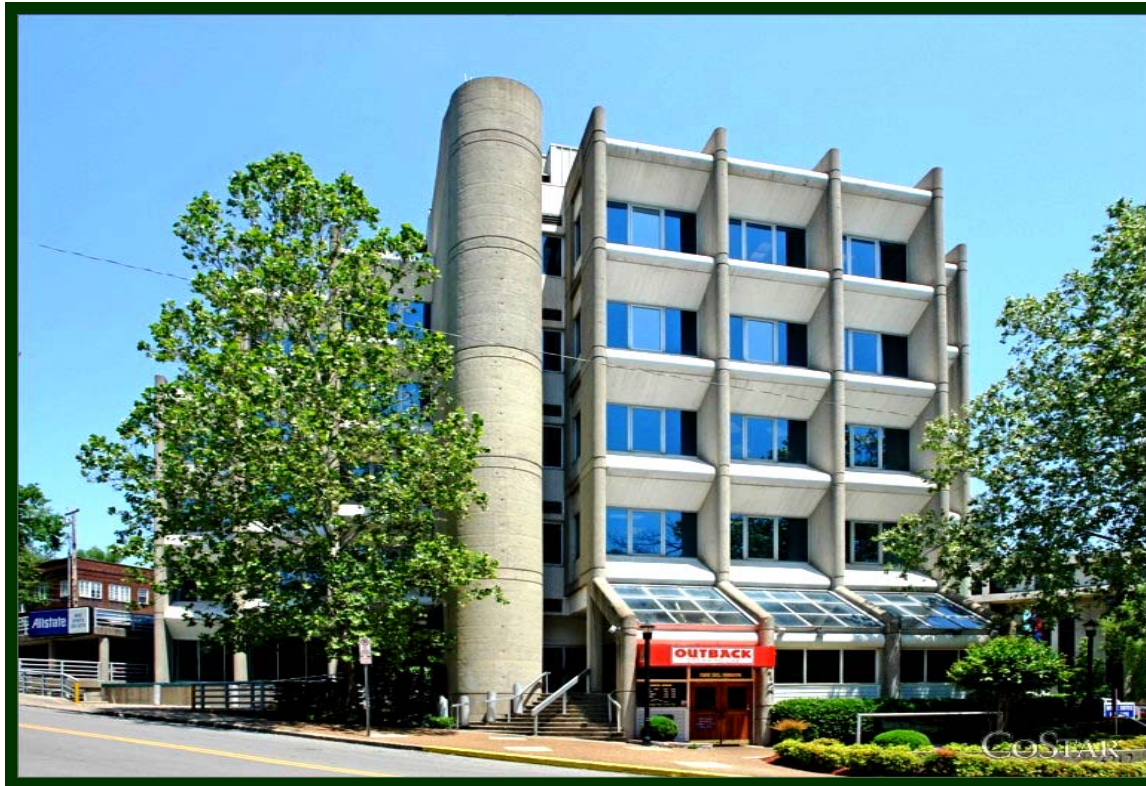

Exclusively Listed by
Chas. Hawkins Co., Inc. / CORFAC
International
www.chashawkins.com

R. Stephen Prather
615.345.7254 (office)
615.818.8429 (cell)
sprather@chco.com

Kim Camp
615.345.7226 (office)
615.477.6327 (cell)
kcamp@chco.com

Office Suites Available for Lease at 3212 West End Ave – Westpark Building

776 Melrose Avenue ♦ Nashville, TN 37211 ♦ Phone 615-256-3189 ♦ 615-254-4026 Facsimile www.chashawkins.com

No warranty or representation, expressed or implied, is made as to the accuracy of the information contained herein, and same is submitted subject to errors, omissions, changes of price, withdrawals without notice, and to any specific conditions imposed by our principal

- **RATES: \$20.00 PER SQUARE FOOT – FULL SERVICE GROSS RATE**
- **FIVE SUITES AVAILABLE FOR LEASE:**
 - **SUITE 200: ±1,250 SQUARE FEET**
 - **SUITE 204: ±700 SQUARE FEET**
 - **SUITE 301: ±2,442 SQUARE FEET**
 - **SUITE 400: ±1,408 SQUARE FEET**
 - **SUITE 402: ±1,733 SQUARE FEET**
- **PROPERTY IS LOCATED AT 3212 WEST END AVENUE**
- **±37,733 SQUARE FOOT BUILDING**
- **FIVE STORIES**
- **PROPERTY SITS ON 0.42 ACRES**
- **15 FREE STRIPED PARKING SPACES IN SURFACE PARKING LOT**
- **60 FREE STRIPED PARKING SPACES IN COVERED PARKING GARAGE**
- **OUTBACK STEAKHOUSE ON SITE**
- **ON SITE PROPERTY MANAGEMENT**

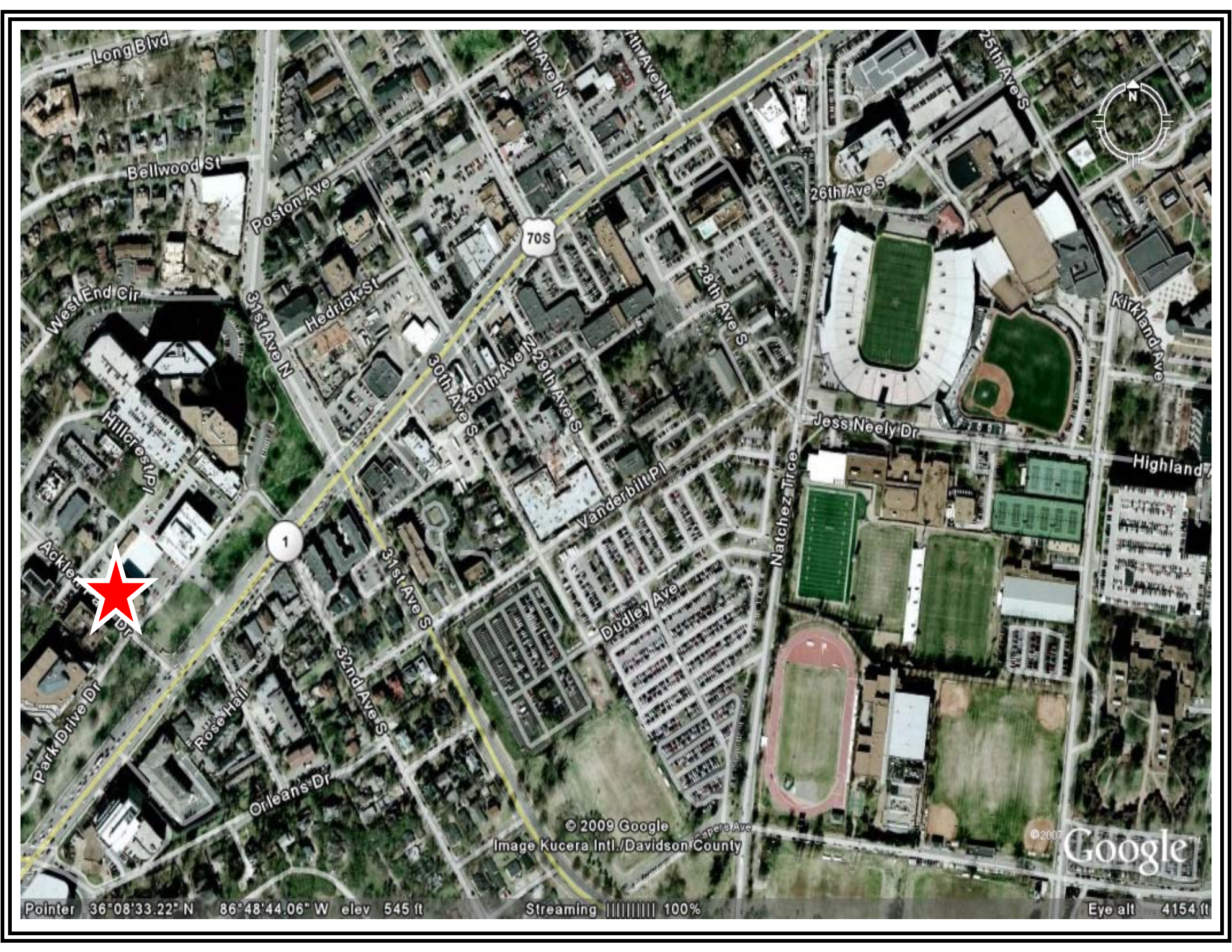

70S

1

© 2009 Google
Image Kucera Intl./Davidson County

© 2007
Google

Pointer 36°08'33.22" N 86°48'44.06" W elev 545 ft

Streaming ||||| 100%

Eye all 4154 ft

Suite 200

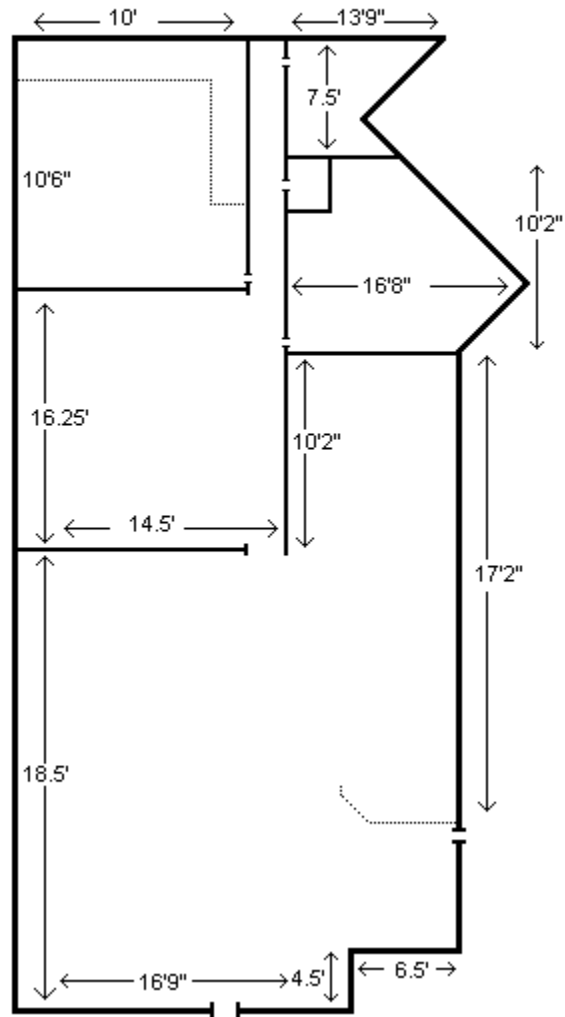

Suite 204

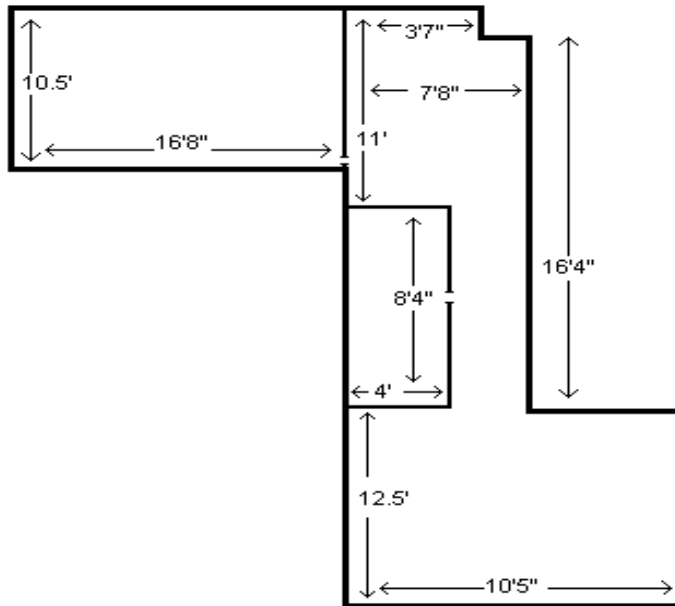

Suite 301

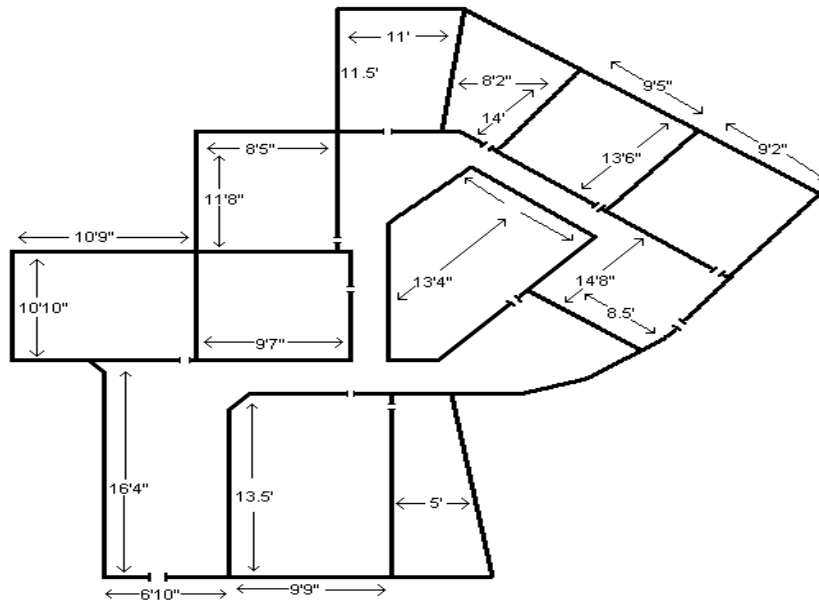

Suite 402

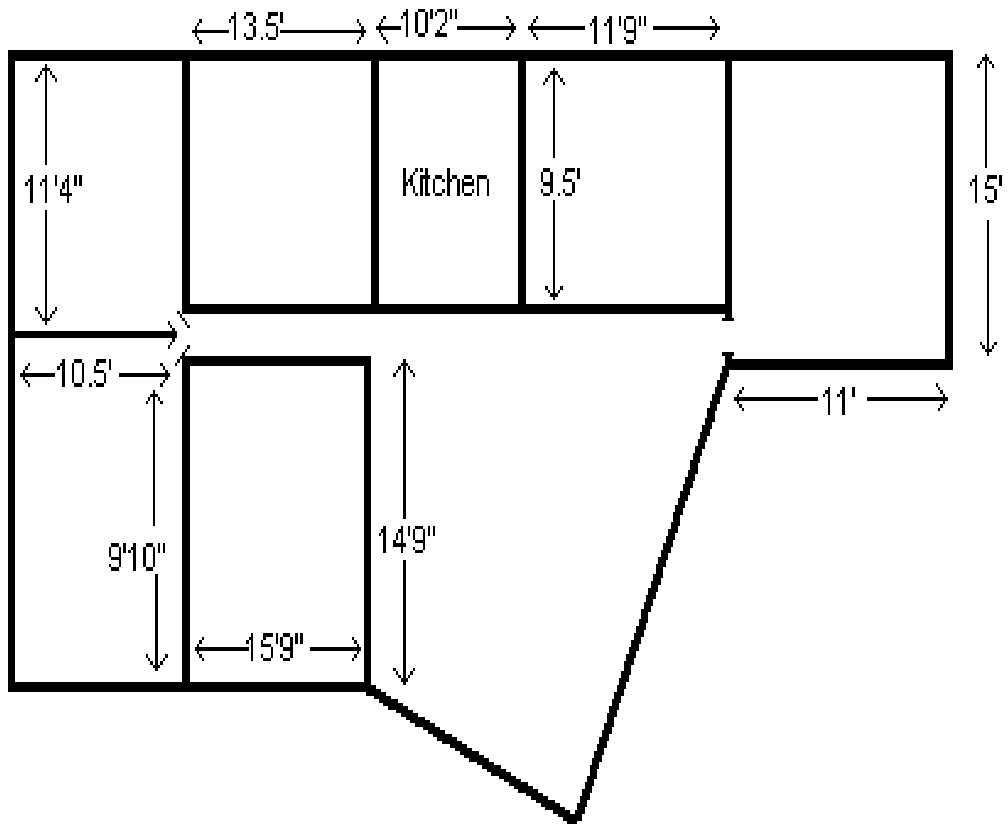

**3212 West End Suite 400
Cosmetic Office Floorplan**

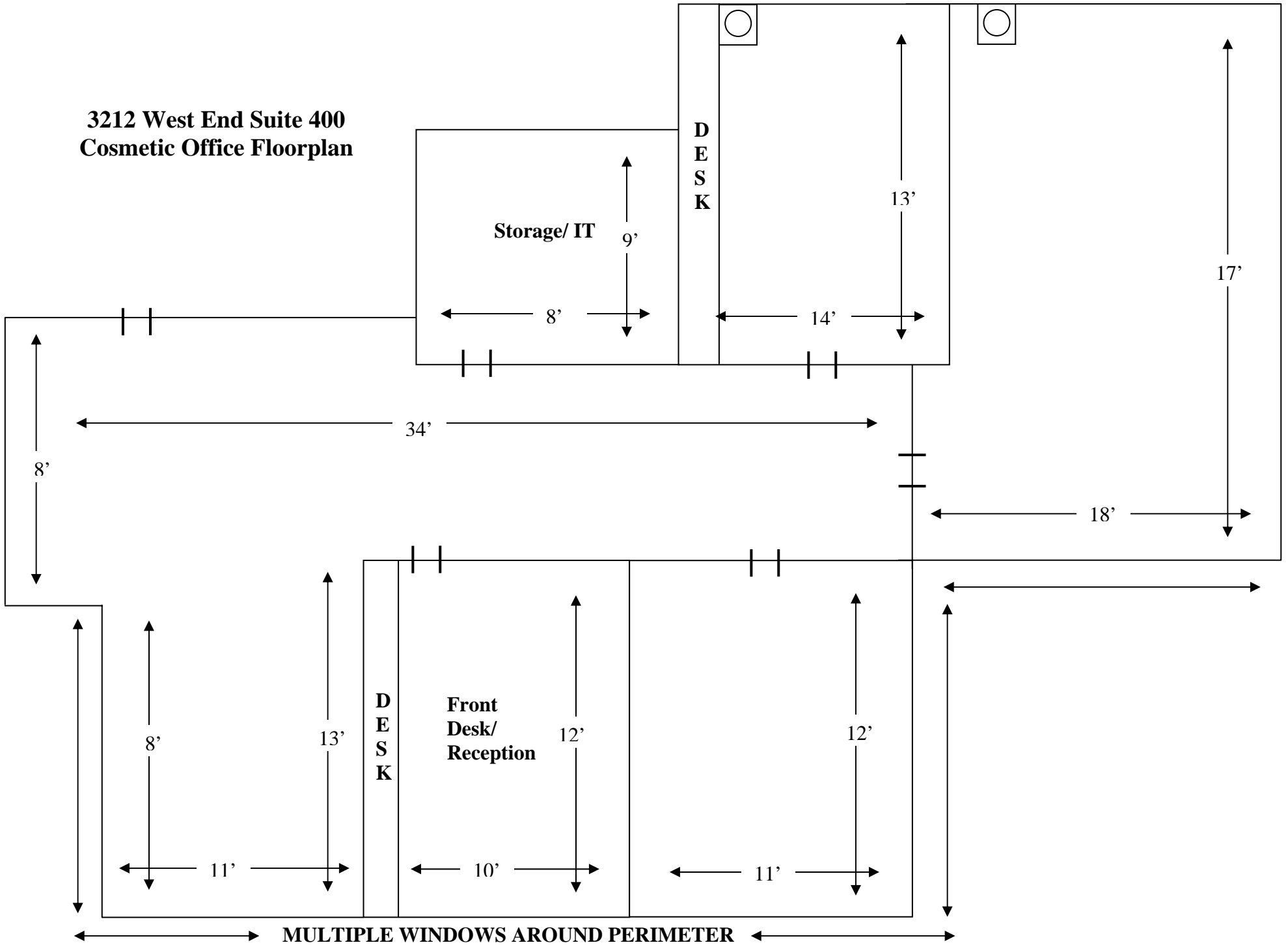

MULTIPLE WINDOWS AROUND PERIMETER